

150 NOS. C.S.K. BOLTS M22x75 LG. (WITH SPARE)

NOTES:-

1. ALL DIMENSIONS ARE IN mm.
2. ALL HSFQ BOLTS ARE CL-8.8 (AS PER RDSO. DRG. NO. B-11760/R) CONFORMING TO IS:4000-1992, IS: 3757-1985 (REAFFIRMED 2003).
3. ALL NUTS ARE CONFORMING TO IS:6623-2004 & IS:1367, PART-6 & PLAIN WASHERS ARE CONFORMING TO IS:6649.
4. EACH HSFQ HEX. HD. BOLT CONSIST OF ONE DTI WASHER, ONE PLAIN WASHER & ONE HEX. HD. NUT.
5. ALL BOLTS, NUTS & WASHERS MUST HAVE IDENTIFICATION MARK & MANUFACTURER'S SYMBOL & PROPERTY CLASS.
6. ALL BOLTS, NUTS & WASHERS MUST HAVE MANUFACTURER'S TEST CERTIFICATE IN ADDITION THREE SETS OF RANDOM SAMPLE CONSISTING OF 1 NO. Hex. HD. BOLT+Hex. HD. NUT+PLAIN WASHER FROM EACH LOT TO BE SENT TO REPUTED INDEPENDENT NABL ACCREDITED LABORATORY.
7. ALL BOLTS, NUTS & WASHERS SHOULD HAVE COATING OF ZINC PHOSPHATE AS PER IS 1367 (PART-XII).
8. FOR DETAILS OF CSK HEAD REFER EN 14399-PART-7.

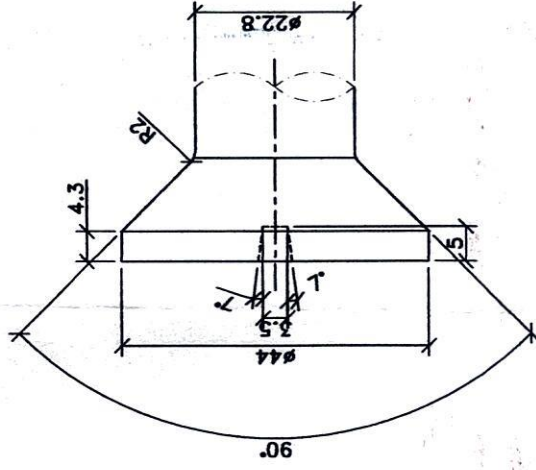

VIEW-A-A



THE BRAITHWAITE BURN & JESSOP CONSTRUCTION COMPANY LIMITED, KOLKATA
(A GOVT. OF INDIA ENTERPRISE)

CLIENT: **SOUTH WESTERN RAILWAY**

PROJECT: **25 Ton. AXLE LOADING STANDARD-2008**

9x45.7 M SPAN OPEN WEB WELDED THROUGH TYPE GIRDER FOR BR.NO.-65D
GADAG-HOTGI DOUBLING PROJECT

SCALE:- 1:2 NAME DATE TITLE:

DRAWN BY: **A.K.SETHI** 29.07.24 DETAILS OF C.S.K. BOLTS AT LO & L8 JOINT

CHECKED BY: **S.MUMDER** 29.07.24

APPROVED BY: B.B.J. SKETCH NO.- 2151-SK-02

B.B.J. ORDER NO.- 2151 SHEET SIZE:- A4 REV.

RECON. NO. - D/3551

DATE :- 08.08.2024