

REQUIRED 40 NOS. (INCLUDING 8 NOS. SPARE)
38 DIA TURNED & FITTED BOLTS; CLASS 8.8
FOR FIXING BEARING SADDLE PLATE WITH BOTTOM CHORD

NOTE:-

1. ALL DIMENSIONS ARE IN MM.
2. BOLTS & NUTS ARE OF CLASS- 8.8 & 8 & M.S WASHER
3. FOR BEARING REFER RDSO DRG. NO.- RDSO/B-17164, ALT-2
& BOTTOM CHORD JOINT REF. DRG. NO.-RDSO/B-17170R.



**THE BRAITHWAITE BURN AND JESSOP
CONSTRUCTION COMPANY LIMITED
(A GOVT. OF INDIA ENTERPRISE)**

CLIENT: NORTH EASTERN RAILWAY			
PROJECT: 25Ton. AXLE LOADING STANDARD-2008, OPEN WEB WELDED THROUGH TYPE GIRDER FOR BR.NO.-50(14x61.0M) SPAN FOR BETWEEN PANIAHWA-VALMIKINAGAR DOUBLING, BR.NO 16 (18x61.0M) BETWEEN MANJHI-BAKULAHA STATION OF CPR-BUI DOUBLING, BR.NO 391 (17x61.0M) BETWEEN CHOWKA GHAT- GHAGHRA GHAT OF BUG-GD 4TH LINE PROJECT.			
TITLE: DETAILS OF TURNED & FITTED BOLTS FOR FIXING BEARING SADDLE PLATE WITH BOTTOM CHORD FOR BR NO.16 (2x30.5M SPAN)			
SCALE:- 1:2	NAME	DATE	B.B.J. ORDER NO.- 3144
DRAWN BY:	A.K.SETH	19.02.2026	DRG. NO. 3144-ERC-30.5M-03
CHECKED BY:	S.MAJUMDER	19.02.2026	
APPROVED BY:			REQN.NO.- D/3563
			DATE:20.02.26
			A4

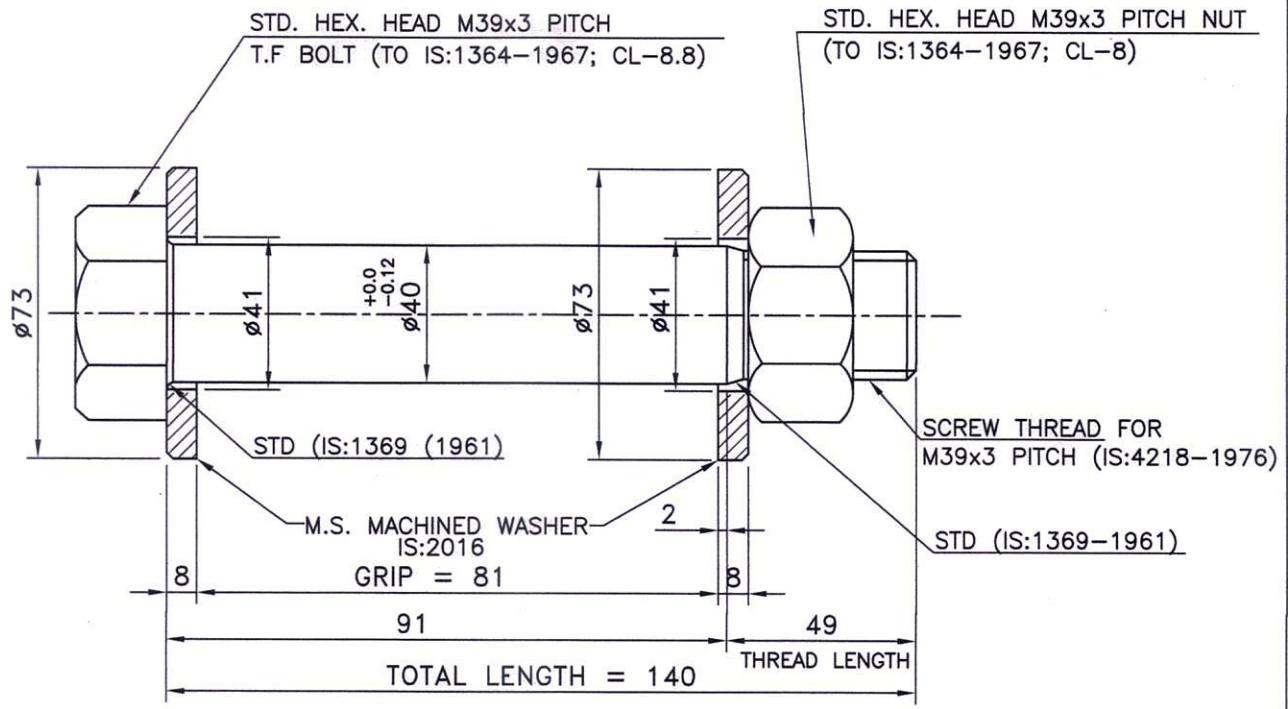

**REQUIRED 300 NOS. (INCLUDING 12 NOS. SPARE)
 40 DIA TURNED & FITTED BOLTS; CLASS 8.8
 FOR FIXING BEARING SADDLE PLATE WITH BOTTOM CHORD**

NOTE:-

1. ALL DIMENSIONS ARE IN MM.
2. BOLTS & NUTS ARE OF CLASS- 8.8 & 8 & M.S WASHER
3. FOR BEARING REFER RDSO DRG. NO.- RDSO/B-17182/3, ALT-3
 & BOTTOM CHORD JOINT REF. DRG. NO.- 2163/61.0M/09 (REV-0)

	THE BRAITHWAITE BURN AND JESSOP CONSTRUCTION COMPANY LIMITED (A GOVT. OF INDIA ENTERPRISE)		
CLIENT:		NORTH EASTERN RAILWAY	
PROJECT: 25Ton. AXLE LOADING STANDARD-2008, OPEN WEB WELDED THROUGH TYPE GIRDER FOR BR.NO.-50(14x61.0M) SPAN FOR BETWEEN PANIAHWA-VALMIKINAGAR DOUBLING, BR.NO 16 (18x61.0M) BETWEEN MANJHI-BAKULAHA STATION OF CPR-BUI DOUBLING, BR.NO 391 (17x61.0M) BETWEEN CHOWKA GHAT- GHAGHRA GHAT OF BUG-GD 4TH LINE PROJECT.			
TITLE: DETAILS OF TURNED & FITTED BOLTS FOR FIXING BEARING SADDLE PLATE WITH BOTTOM CHORD FOR BR NO.16 (18x61.0M SPAN)			
SCALE:- 1:2	NAME	DATE	B.B.J. ORDER NO.- 3144
DRAWN BY:	A.K.SETH	19.02.2026	3144-ERC-61.0M-02
CHECKED BY:	S.MAJUMDER	19.02.2026	
APPROVED BY:			REQN.NO.- D/3563 DATE:20.02.26
			REV. 0 A4